

SANDBLASTER®

Self-Cleaning Commercial Gas Water Heater - SBD Models

Sandblaster® is the original money-saving self-cleaning water heater. It provides outstanding performance and installation flexibility for new construction and replacement applications. The Sandblaster SBD series offers installer-friendly features, including compact low-profile design, multiple options for water connections and low installation clearances.



Hydro Cannon™



Self-Cleaning Hydro Cannon™

- Significantly reduces sediment buildup inside the tank
- Maintains rated thermal efficiency, reduces water heating costs
- Maximizes tank life

Automatic Flue Damper (120 - 390 Models)

- Automatic motorized flue damper helps minimize standby heat loss
- Low-profile draft diverter helps for installation in tight spaces
- SBD85 500 Model features induced draft design and no damper

Three Water Connection Options

- Hot and cold water connections can be made through front, top or rear of unit
- Hydro Cannon™ operates when cold water is connected through front

Intermittent Electronic Ignition

- Eliminates standing pilot, saves energy
- Includes power ON/OFF switch
- Provides flame failure response in less than one second

Glasslined Tank with Multiple Anode Rods

- Provides outstanding protection against corrosion

CSA Certified and ASME Rated T&P Relief Valve, Factory-Installed

Maximum Hydrostatic Working Pressure 160 psi

80% Thermal Efficiency

Meets the Thermal Efficiency and Standby Loss Requirements of the U.S. Department of Energy and Current Edition of ASHRAE/IESNA 90.1

- Design-certified by Underwriters Laboratories (UL), according to ANSI Z21.10.3-CSA 4.3 standards governing storage-type water heaters
- Design-certified by Underwriters Laboratories Sanitation to NSF Standard 5 for 180°F (62°C) water
- Optional ASME tank construction available

Three-Year Limited Tank Warranty

- For complete warranty information, consult written warranty shipped with water heater or contact State Water Heaters

For more information on Sandblaster® contact:
 State Water Heaters
 500 Tennessee Waltz Parkway, Ashland City, TN 37015
 800-365-0024 Toll-free USA
 www.statewaterheaters.com

SOLID.STATE.



SANDBLASTER®

Self-Cleaning Commercial Gas Water Heater - SBD Models

Other Sandblaster® Features

Fully Automatic Control System

- Manual-reset gas shut-off device prevents excessive water temperature
- Adjustable thermostat with 120° - 180° range
- Gas pressure regulator and pilot filter

Handhole Cleanout

- Allows easy access to tank interior for cleaning

Plug Kits

- Pipe nipples and caps included to plug unused water connections

Sandblaster® Options

Manifold Kits for Multiple Heater Installations

- 2-unit kit, Part Number 9003426205
- 3-unit kit, Part Number 9003427205
- 4-unit kit, Part Number 9003428205

Optional Leg Kit to Meet NSF Standard 5

- For all SBD models, Part Number 9003425205

Side Wall Power Venting Kits

- For SBD71 120NE through SBD100 199NES, Part Number 9006015005
- For SBD100 250NE through SBD100 390NE, Part Number 9006016005
- For installation of approved power venter to operate in conjunction with water heater thermostat
- Field wiring should conform to latest version of the National Electric Code ANSI/NFPA No. 70
- For more information, consult manual shipped with water heater or contact the State Water Heaters Technical Support Center at 1-800-365-0024

WATER CONNECTIONS IN INCHES	
TOP INLET AND OUTLET	1-1/2" on all models except SBD65 251 and SBD65 305, not equipped with top connections
FRONT INLET AND OUTLET	1-1/2" on all models except 2" on SBD100 199NES, SBD100 250, SBD100 275 and SBD 100 390
BACK INLET AND OUTLET	1-1/2" on all models except 2" on SBD100 199NE, SBD100 250, SBD100 275 AND SBD100 390

SOLID.STATE.



CAPACITY, INPUT AND OUTPUT

MODEL NUMBER	BTU INPUT PER HOUR	Gallons or Litres	TANK SIZE	FIRST HOUR RATING	GPH or LPH	RECOVERY – GALLONS OR LITRES PER HOUR AT DEGREE RISE		
						40°F	100°F	140°F
						22°C	56°C	78°C
SBD71 120NE	120,000	U.S. Gallons	71	166	GPH	291	116	83
		Litres	268	628	LPH	1102	439	314
SBD81 154NE	154,000	U.S. Gallons	81	206	GPH	373	149	107
		Litres	306	780	LPH	1412	564	405
SBD81 180NE	180,000	U.S. Gallons	81	232	GPH	434	175	124
		Litres	306	878	LPH	1643	662	469
SBD81 199NE	199,000	U.S. Gallons	81	263	GPH	461	184	132
		Litres	306	995	LPH	1745	697	500
SBD100 199NET	199,000	U.S. Gallons	100	263	GPH	482	193	138
		Litres	379	995	LPH	1825	731	522
SBD100 199NE	199,000	U.S. Gallons	100	241	GPH	482	193	138
		Litres	379	912	LPH	1825	731	522
SBD100 199NES (A)	199,000	U.S. Gallons	100	263	GPH	482	193	138
		Litres	379	995	LPH	1825	731	522
SBD100 250NE (A)	250,000	U.S. Gallons	100	312	GPH	606	242	173
		Litres	379	1181	LPH	2294	918	655
SBD65 251NE (A)	251,000	U.S. Gallons	65	289	GPH	608	243	174
		Litres	246	1094	LPH	2303	921	658
SBD100 275NE (A)	275,000	U.S. Gallons	100	337	GPH	667	267	190
		Litres	379	275	LPH	2524	1009	721
SBD65 305NE (A)	305,000	U.S. Gallons	65	342	GPH	739	296	211
		Litres	246	1294	LPH	2799	1120	800
SBD85 365NE (A)	365,000	U.S. Gallons	85	314	GPH	885	354	253
		Litres	322	1188	LPH	3349	1340	957
SBD100 390NE (A)	390,000	U.S. Gallons	100	458	GPH	945	387	270
		Litres	379	1733	LPH	3576.8	1464.9	1022
SBD85 500NE (A)*	500,000	U.S. Gallons	85	545	GPH	1212	479	346
		Litres	322	2062	LPH	4588	1813.2	1311

Maximum gas supply pressure (natural and propane gas): 13.8" w.c.

Minimum gas supply pressure, natural gas: 4.5" w.c. Minimum gas supply pressure, propane gas: 10" w.c.

Manifold pressure, natural gas: 3.5" w.c. Manifold pressure, propane gas: 10" w.c.

Electrical requirements: 120 VAC, .7 Amp, Electrical requirements with Power Venter: 120 VAC, 3.0 FLA Amps

*Induced Draft design, Category I Venting

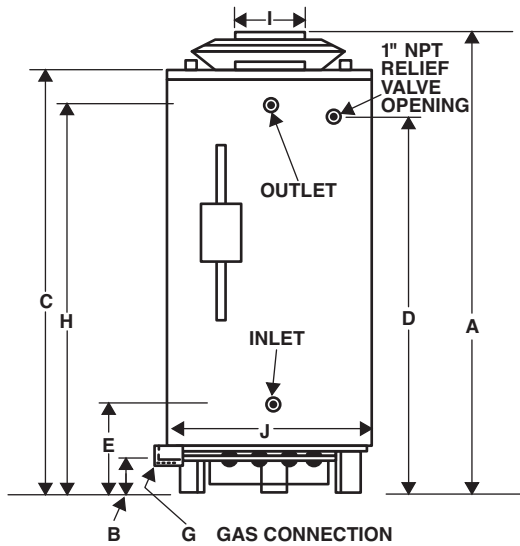

**MODELS
SDB85 120-390**

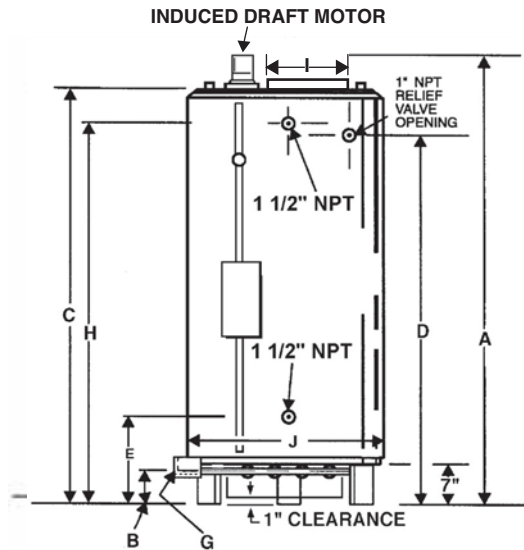

**MODEL
SDB85 500**

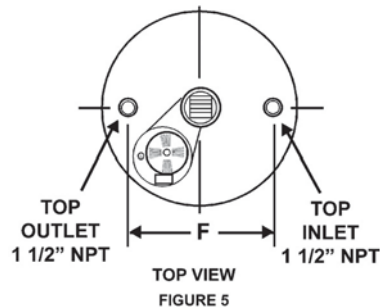
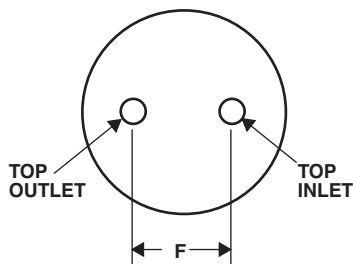

FIGURE 5

SANDBLASTER®

Self-Cleaning Commercial Gas Water Heater - SBD Models

DIMENSIONS AND SHIPPING WEIGHTS

MODEL NUMBER	Inches or CM	DIMENSIONS										SHIPPING WEIGHT	
		A	B	C	D	E	F	G	H	I	J	STANDARD	ASME
SBD71 120NE*	Inches	69-3/4	4-1/4	59-1/2	50-7/8	19-11/16	19	1/2	51-7/8	6	27-3/4	400 Lbs.	N/A
	CM	177	11	151	129	50	48	-	132	13	70	181 Kg	
SBD81 154NE	Inches	73	4-1/4	66-1/2	57-7/8	19-11/16	19	1/2	59	6	27-3/4	470 Lbs.	N/A
	CM	185	11	169	147	50	48	-	150	15	70	213 Kg	
SBD81 180NE	Inches	67-1/2	4-1/2	62	53-5/8	20-1/2	21	1/2	54-5/8	6	27-3/4	470 Lbs.	N/A
	CM	171	12	157	136	52	53	-	139	15	70	213 Kg	
SBD81 199NE	Inches	67-1/2	4-1/2	62	53-5/8	20-1/2	21	1/2	54-5/8	6	27-3/4	470 Lbs.	N/A
	CM	171	12	157	136	52	53	-	139	15	70	213 Kg	
SBD100 199NET	Inches	75	4-1/2	70	61-5/8	20-1/2	21	1/2	61-1/2	6	27-3/4	603 Lbs.	N/A
	CM	192	12	178	157	52	53	-	150	15	70	273 Kg	
SBD100 199NE	Inches	75	4-1/2	70	61-5/8	20-1/2	21	1/2	61-1/2	6	27-3/4	603 Lbs.	N/A
	CM	192	12	178	157	52	53	-	150	15	70	273 Kg	
SBD100 199NES (A)	Inches	72	4-1/2	65-1/8	55-7/8	19-3/4	23	1/2	56-3/8	6	30-1/4	630 Lbs.	725 Lbs.
	CM	183	12	165	142	50	58	-	143	15	77	286 Kg	329 Kg
SBD100 250NE (A)	Inches	72	4-1/2	65-1/8	55-7/8	19-3/4	23	1/2	56-3/8	8	30-1/4	630 Lbs.	725 Lbs.
	CM	183	12	165	142	50	58	-	143	20	77	286 Kg	329 Kg
SBD65 251NE (A)	Inches	75	4-1/2	65-3/4	57-1/4	20	N/A	1/2	58-3/4	8	27-3/4	750 Lbs.	862 Lbs.
	CM	191	12	167	145	51	N/A	-	149	20	70	341 Kg	391 Kg
SBD100 275NE (A)	Inches	72	4-1/2	65-1/8	55-7/8	19-3/4	23	1/2	56-3/8	8	30-1/4	630 Lbs.	725 Lbs.
	CM	183	12	165	142	50	58	-	143	20	77	286 Kg	329 Kg
SBD65 305NE (A)	Inches	75	4-1/2	65-3/4	57-1/4	20	N/A	1/2	58-3/4	8	27-3/4	750 Lbs.	862 Lbs.
	CM	191	12	167	145	51	N/A	-	149	20	70	341 Kg	391 Kg
SBD85 365NE (A)	Inches	79-1/2	4-1/2	70-1/4	62-1/2	22-1/2	23	3/4	63	8	27-3/4	725 Lbs.	833 Lbs.
	CM	202	12	178	159	57	58	-	160	20	70	329 Kg	379 Kg
SBD100 390NE (A)	Inches	75-1/2	4-1/2	67-1/2	58-1/4	26-3/4	23	3/4	59	8	30-1/4	760 Lbs.	874 Lbs.
	CM	192	12	171	148	68	58	-	150	20	77	345 Kg	396 Kg
SBD85 500NE (A)	Inches	81-1/2	17-1/2	77-1/4	67-1/2	27	21	1	67-1/2	8	27-3/4	812 Lbs.	857 Lbs.
	CM	207	44.5	196.2	171.5	68.6	53.3	2.5	171.5	20.3	70.5	368 Kg	388 Kg

SBD65 251NE, SBD100 250NE and SBD100 275NE models shipped with 8" to 6" vent reducer. Certified for both 6" or 8" vent.

*SBD71 120NE approved for 5" venting using field supplied 6" to 5" reducer.

SUGGESTED SPECIFICATION

(Natural or Propane) gas water heater(s) shall be State Sandblaster® model # _____ or equal, with a storage capacity of _____ gallons, an input rating of _____ BTUs per hour, a recovery rating of _____ GPH at 100°F rise and a maximum hydrostatic working pressure of 160 psi. Water heater(s) shall be protected against overheating caused by the buildup of scale, film and other sediment by a self-cleaning device, positioned inside the tank so that it directs the flow of inlet water to keep precipitated solids in suspension so that they are removed from the water heater on that or successive draws. Glasslined water heater(s) shall also be protected against electrolytic corrosion by multiple factory-installed anode rods. In addition, water heater(s) shall: 1) Be equipped with an integrated control system consisting of a 180°F adjustable thermostat with upper and lower sensing bulbs. 2) Be equipped with intermittent electronic ignition, a manual reset gas shutoff device, a gas pressure regulator, factory-installed CSA Certified and ASME Rated T&P Relief valve and 2-3/4" x 3-3/4" tank inspection port. 3) Be design-certified by Underwriters Laboratories under Volume III tests for commercial water heaters for delivery of 180° water. 4) Be design-certified by UL (Underwriters Laboratories) to current edition of ANSI Z21.10.3 - CSA 4.3 standards governing storage-type water heaters. 5) Meet the thermal efficiency and standby loss requirements of the U.S. Department of Energy and Current Edition of ASHRAE/IESNA 90.1. 6) Have a 3-year limited warranty as outlined by manufacturer.

For complete information on limited warranties, consult written warranty, or contact the State Customer Care Center, 1-800-365-0024.

State Industries, Inc. reserves the right to make product changes or improvements without prior notice

For more information on Sandblaster® contact:
 State Water Heaters
 500 Tennessee Waltz Parkway, Ashland City, TN 37015
800-365-0024 Toll-free USA
www.statewaterheaters.com

SOLID.STATE.

