

Commercial Vertical Round Electric Brute



150 to 1000 Gallons Storage
15 to 396 kW
Round Vertical Models
Outstanding Safety Features

The Electric Brute Water Heater Models Feature:

- 125 PSI ASME Code Glass-Lined Tank
- Incoloy Heating Elements
- Internal Fusing (above 120 amps)
- Enamel Finished Steel Jacket
- Magnesium Anode Rods
- Immersion Thermostats
- Magnetic Contactors
- Manual Reset High Limit
- Hinged Door With Keyed Lock
- ASME Temperature and Pressure Relief Valve
- Channel Iron Skid Base
- Hand Hole Cleanout
- Approved for 180°F (82.2°C) Operation
- Three-year Limited Warranty

Optional Equipment Features:

- Low Water Cut-off
- Pilot Lights
- Manual Limiting Switches
- Alarm Bell
- Low or High Pressure Switch
- Time Clock (7 Day or 24 Hour)†
- Safety Door Interlock
- Temperature and Pressure Gauge
- Man Hole Cleanout (250 Gallons and Larger)
- 150 PSI Working Pressure
- Electronic Step Controller (36kW & Higher)
- Shunt Trip Disconnect†

†Separate mounting.

3 Year Limited Tank Warranties.

For more information on warranty, please visit www.bradfordwhite.com

For products installed in USA, Canada and Puerto Rico. Some states do not allow limitations on warranties. See complete copy of the warranty included with the heater.



Commercial Electric Brute Water Heaters

Standard Equipment Features:

Energy-Saving Performance - A heavy blanket of high-density fiberglass insulation is used to meet the demanding ASHRAE 90.1b current standard for minimizing heat loss. This requirement, allowing a maximum 4 watts per square foot of tank surface energy loss, offers big savings and operating efficiency.

Magnetic Contactors with Immersion Thermostats - 120 volt control circuit with built in transformer. Elements are thermostatically controlled in 54kW (max) increments.

Low Watt Density Incoloy Elements - Incoloy elements are used by Bradford White because of their many superior characteristics to copper-sheathed elements in rigorous water heating applications. This tough alloy successfully resists the effects of prolonged high operating temperatures, hard water, acids, corrosion, and thermal shock. Their nominally higher initial cost is more than offset by much longer life expectancies and reduced service and replacement labor costs. Incoloy elements are designed to "burn in air" to prevent failures caused by water void.

Internal Fusing - All elements and circuits are fused in 48 amp increments, providing complete electrical protection. Cartridge type fuses are rated at 200,000 ampere interrupting capacity.

Glass-Lined Tank - Vitreous glass is applied to the inside surface of the steel tank and fired to 1600°F. (All models are constructed in accordance with the ASME code and approved for 125 PSI working pressure.)

Magnesium Tank Saver - Provides anodic protection against corrosion of the tank due to electrolysis.

Galvanized Jacket - The heavy 16-gauge steel jacket is galvanized on both sides and beautifully finished in durable acrylic enamel. This combines attractive appearance with maximum protection.

Full-Length Hinged Door with Key Lock - Quality requires full-length hinged doors for ease of inspection and maintenance. Keyed door lock provides additional safety and security at no extra charge.

Temperature and Pressure Relief Valve - Factory provided ASME rated relief valve protects against excessive temperature and/or pressure buildup within the tank.

Terminal Block Connections - Easy and safe wiring connections are made possible by factory installed terminal blocks.

180°F Temperature Operation - Every Electric Brute Heater is approved for 180°F operation for sanitizing and other high-temperature requirements.

Hand Hole Cleanout - Provides easy access to the heater interior for inspection and cleaning.

UL Listed - All models are listed by Underwriters Laboratories, Inc. as commercial electric water heaters. This assures competent design and proper testing.

Three-Year Limited Warranty - Provides warranty protection against tank failure resulting from defects in material and workmanship.

Channel iron skid base.

Optional Equipment Features:

Low Water Cut Off - Prevents energizing of the heater when not filled with water or upon low water condition.

Pilot Lights - Monitor on/off cycle for each contactor.

Manual Limiting Switches - With indicating lights – permits manual limitation of heating input by switching off current to each contactor.

Solid State Modulating Control (Electronic Step Controller) - Modulates power input and balances load to demand. Contactors are staged automatically and sequentially to equalize element usage. Unit reprograms to "off" position on power failure.

Alarm Bell - Warns of various control failures.

Shunt Trip Disconnect† - Provides maximum protection by interrupting all power to the system in the event of a control sensed malfunction or overcurrent.

Low or High Pressure Switch - Turns off control circuit when water pressure drops below a set minimum, or above a set maximum.

Time Clock† - To control off/on cycles of the heater as programmed by the owner or electric utility requirements. (7 day or 24 hour).

Safety Door Interlock - Prevents opening of access door while heater is energized.

Temperature and Pressure Gauges - Jacket mounted for convenient viewing.

Man Hole - Provides means to easily remove sediment from the heater; optional on 250 gallon and larger.

Working pressure - 150 PSI ASME construction.

†Separate mounting.

Commercial Electric Brute Water Heaters

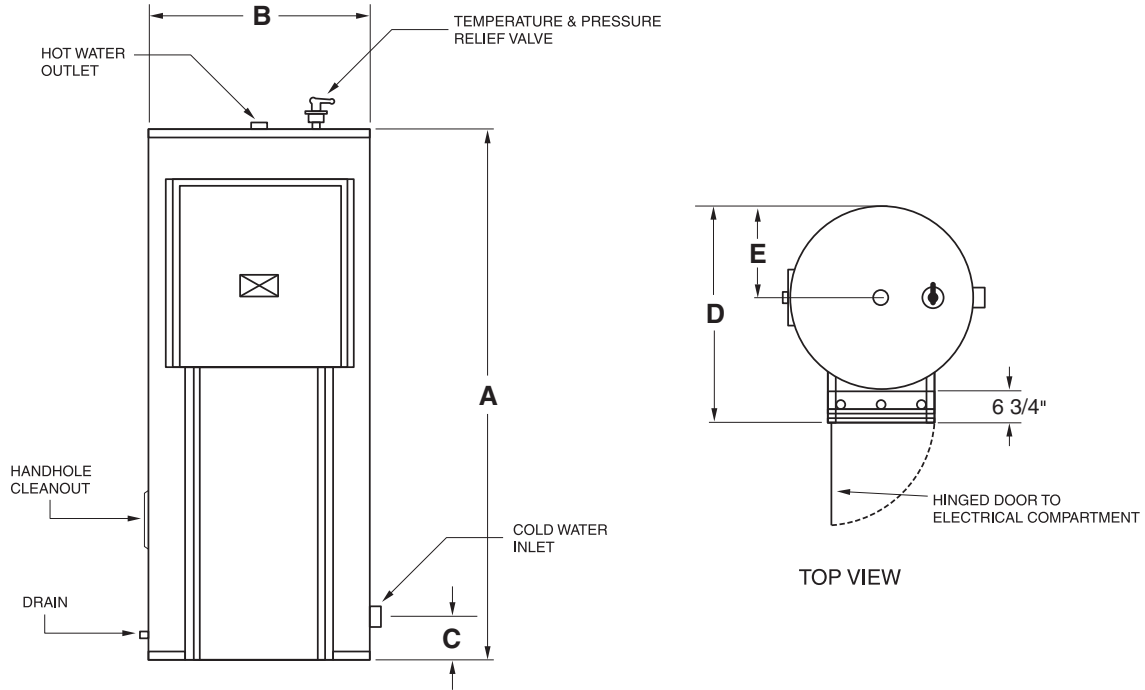

Commercial Vertical Round Electric Brute

Meet or exceed ASHRAE 90.1b (current standard)

Model Number	Gallon Capacity	Maximum kW	A Floor to Top of Heater in.	B Jacket Dia. in.	C Floor to Cold Water Inlet in.	D Depth in.	E Back of Heater to Hot Water Outlet in.	Water Conn. in.	Approx. Shipping Weight lbs.
VR150-(kW)	150	135	65 ¹ / ₂	32	7 ³ / ₄	38 ³ / ₄	16	1 ¹ / ₂	650
VR200-(kW)	200	180	78	32	7 ³ / ₄	38 ³ / ₄	17	1 ¹ / ₂	750
VR250-(kW)	250	216	92	34	19 ¹ / ₂	40 ³ / ₄	17	1 ¹ / ₂	1165
VR300-(kW)	300	270	80	40	21	46 ³ / ₄	20	2	1350
VR400-(kW)	400	360	80	46	22 ¹ / ₂	52 ³ / ₄	23	2	1590
VR500-(kW)	500	396	92	46	22 ¹ / ₂	52 ³ / ₄	23	2	1700
VR600-(kW)	600	396	92	54	24 ¹ / ₂	60 ³ / ₄	27	2 ¹ / ₂	2010
VR800-(kW)	800	396	104	54	24 ¹ / ₂	60 ³ / ₄	27	2 ¹ / ₂	2450
VR1000-(kW)	1000	396	128	54	24 ¹ / ₂	60 ³ / ₄	27	2 ¹ / ₂	3160

On models VR250 and up dimensions include channel iron legs (not shown).

**Note: Vertical Round models above 90kW at 208V, 240V or 380V, and 162kW at 400V, 415V or 480V, exceed the capacity of a single control panel and may require multiple control panels. Consult the factory for specific details and optional construction.

Commercial Electric Brute Water Heaters

Standard kW Input and Amperage

kW	GPH Recovery 100°F Rise	BTU/Hr. Equivalent	Number of Control Steps	Maximum Number of Elements	kW Size of Element	Contactor Option		Amperage Draw							
						No. of Contactors (208,240)/ (380,400,415,480)	Suggested Control Steps (208,240) / (380,400,415,480)	Single Phase		Three Phase					
								208V	240V	208V	240V	380V	400V	415V	480V
12	49	40,944	1	1	12	1/1	—	58	50	33	29	19	17	17	14
15	62	51,180	1	1	15	1/1	—	72	63	42	36	23	22	21	18
18	74	61,416	1	1	18	2/1	—	87	75	50	44	28	26	25	22
30	123	102,360	1	2	15	2/1	—	144	125	83	72	46	44	42	36
36	148	122,832	1	2	18	4/2	4/2	174	150	100	87	55	51	50	44
45	185	153,540	1	3	15	3/2	3/2	216	188	125	108	69	66	63	54
54	221	184,248	1	3	18	6/2	3/2	260	225	150	130	83	78	75	65
60	246	204,720	2	4	15	12/6	4/3	289	250	167	144	92	88	83	72
72	295	245,664	2	4	18	8/4	4/4	—	—	200	174	110	104	100	87
90	369	307,080	2	6	15	6/3*	3/3	—	—	250	217	137	132	125	109
108	443	368,496	2	6	18	12/4**	4/4	—	—	300	260	165	156	150	130
120	492	409,440	3	8	15	8/4***	4/4	—	—	333	289	183	176	167	144
135	554	460,620	3	9	15	9/6	4/4	—	—	375	325	206	198	188	162
144	590	491,328	3	8	18	16/8	4/4	—	—	400	347	219	208	200	174
162	664	552,744	3	9	18	18/6****	8/6	—	—	450	389	247	234	225	195
180	738	614,160	4	10	18	20/10	8/8	—	—	500	434	273	260	250	217
216	886	736,992	4	12	18	24/8	8/8	—	—	600	519	328	312	301	260
234	959	798,408	5	13	18	26/13	8/8	—	—	650	563	355	338	326	282
252	1033	859,824	5	14	18	28/14	8/8	—	—	700	607	383	364	351	304
270	1107	921,240	5	15	18	30/10	12/10	—	—	750	649	410	390	376	325
288	1181	982,656	6	16	18	32/16	12/12	—	—	800	692	438	416	401	347
306	1255	1,044,072	6	17	18	34/17	12/12	—	—	850	736	465	442	426	368
324	1328	1,105,488	6	18	18	36/12	12/12	—	—	900	780	492	468	451	390
342	1402	1,166,904	7	19	18	38/19	12/12	—	—	950	822	520	494	476	412
360	1476	1,228,320	7	20	18	40/20	12/12	—	—	1,000	865	547	520	501	435
378	1550	1,289,736	7	21	18	42/14	14/14	—	—	1,050	909	574	546	526	455
396	1624	1,351,152	8	22	18	44/22	15/16	—	—	1,100	952	602	572	551	477

For kW inputs not shown above consult factory.

*380V has 4

**380V has 6

***380V has 8

****380V has 9

Typical Specifications

Water Heater(s) shall be Bradford White Electric Brute Series model number _____ with _____ gallons storage capacity, rated at _____ kilowatts, _____ volts, _____ phase. Heater to be completely insulated and jacketed for vertical installation. The jacket shall be round 16-gauge galvanized steel with acrylic enamel finish. Jacket shall have a full-length hinged access door with keyed lock. Tank insulation shall be high-density fiberglass sufficient to meet ASHRAE 90.1b current standard standards of 4 watts per square foot of tank surface maximum energy loss. Keyed Lock Door provides additional safety and security.

Tank construction shall be of maximum allowable working pressure as per ASME standard and be ASME stamped and National Board listed. All tanks are to be lined with vitreous glass, fired at 1600°F (871°C) by a process which provides a molecular interchange of glass and steel.

Electric Brute Series heater shall include the following standard features: magnetic contactors with immersion thermostats, internal fusing for control and load circuits, low-watt density Incoloy sheath elements, ASME rated temperature and pressure relief valve, terminal block wiring, 180°F (82°C) water temperature approval, UL listing, 3-year limited warranty.

Dimensions and specifications subject to change without notice in accordance with our policy of continuous product improvement.



For U.S. and Canada field service, contact your professional installer or local Bradford White sales representative.

Sales 800-523-2931 • Fax 215-641-1670 / Technical Support 800-334-3393 • Fax 269-795-1089 • Warranty 800-531-2111 • Fax 269-795-1089

International: Telephone 215-641-9400 • Telefax 215-641-9750 / www.bradfordwhite.com

BRADFORD WHITE-CANADA INC. Sales / Technical Support 866-690-0961 / 905-238-0100 • Fax 905-238-0105 / www.bradfordwhite.com

Built to be the Best™

©2013, Bradford White Corporation. All rights reserved.